



**LEADING THE WORLD  
IN DIE CUTTING TECHNOLOGY**

# **SYSTEM 2000FT**

**AUTO FEED / DIE CUT / BANDING**

***High Output***

***Fully Automatic***

***Servo Driven***

***Efficient***

***Reliable***



The all new PMC **System 2000FT** Die Cutting Machine combines high output die cutting with the convenience of banding and automatic feeding, all in one easy-to-set-up machine. Combining the Model 2000 with the feed table, makes the **System 2000FT** the fastest label producing equipment in the industry. The **System 2000FT** combines the proven features of the PMC Die Cutting Machines, with state-of-the-art single stroke banding, and feeding concepts, to ensure the **System 2000FT** to be the new industry standard.

# SYSTEM 2000FT

## AUTO FEED / DIE CUT / BANDING



- ▶ Four-sided guiding system jogs and holds the stacks on all four sides during the cutting operation for precise die cutting.
- ▶ The integrity of the stack is maintained from the die cut, throughout the banding operation.
- ▶ Convenient adjustment of die and guides with clear view of die register on labels, speeds set-up and reduces waste.
- ▶ Adjustable banding head allows north-south or east-west banding and can be adjusted laterally.
- ▶ Precise programmable feeder accurately delivers product to the die cutter.
- ▶ Typical uses: labels, note pads, credit cards, identification tags, post cards, game cards, 3-way trim, round cornering.
- ▶ Typical Materials: paper, plastic, vinyl, Mylar, paperboard.

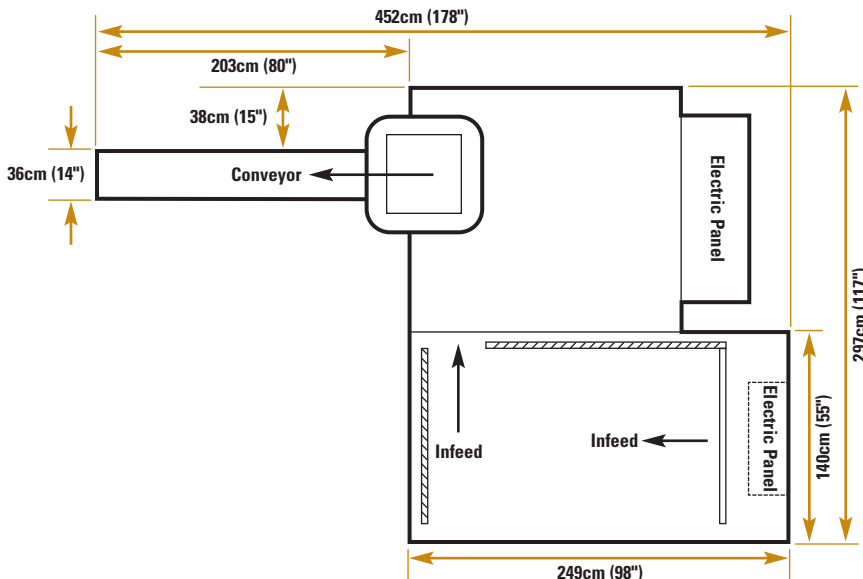

### SPECIFICATIONS: SYSTEM 2000FT

Specifications	System 2000FT	System 2000-912FT
Maximum Pre-cut Size	184mm x 260mm (7.25" x 10.25")	235mm x 311 mm (9.25" x 12.25")
Minimum Pre-cut Size	32mm x 57mm (1.25" x 2.25")	57mm x 83mm (2.25" x 3.25")
Maximum Die Cut Size	178mm x 254mm (7" x 10")	229mm x 305 mm (9" x 12")
Minimum Die Cut Size	25mm x 51mm (1" x 2")	51mm x 76mm (2" x 3")
Recommended Trim	3mm (1/8") all sides	3mm (1/8") all sides
Stack Height	up to 127mm (5")	up to 127mm ( 5")
Cycles Per minute	Variable, 5 to 20	Variable, 5 to 18
Table/Loadable Area	104cm x 117cm(41" x 46")	104cm x 117cm(41" x 46")
Electric Requirements	10hp, 7.5 KVA, 3-phase	10hp, 7.5 KVA, 3-phase
Air Requirements	12.1 m <sup>3</sup> h, 5.5 bars (7.1 CFM, 80psi)	12.1 m <sup>3</sup> h, 5.5 bars (7.1 CFM, 80psi)

### Cutting Edge *Solutions* for Over 60 Years



**PMC** Printing Machinery Company

Division, Stewart Industries, Inc.

7234 Blue Ash Road • Cincinnati, Ohio 45236 USA

513.891.9000 • FAX 513.891.0449

[www.pmcworldwide.net](http://www.pmcworldwide.net)